

# Forming Curves from Layers of Blocks

*Technique offers strength, stability*

by Kirt Kirkpatrick

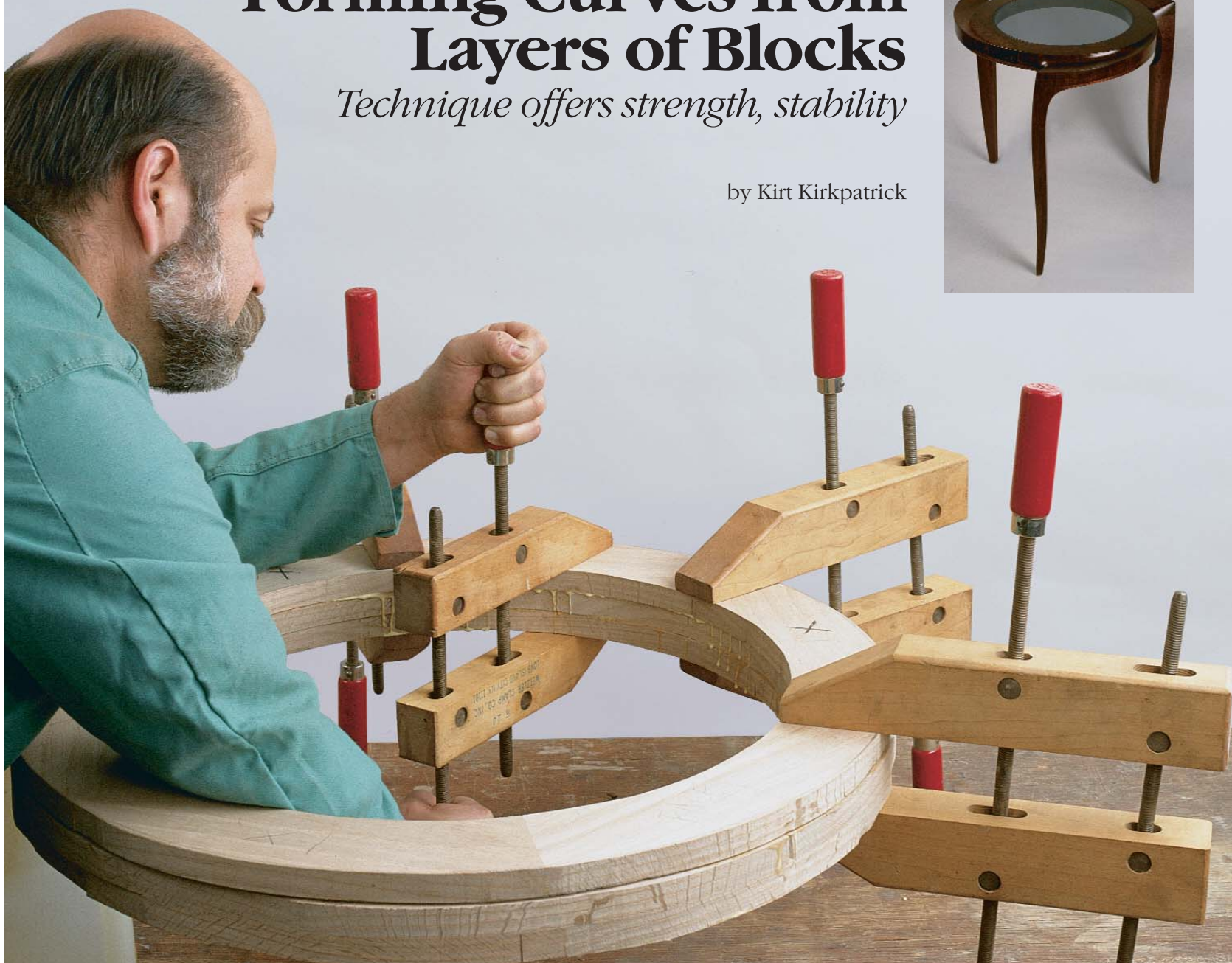

**Bricklaid curves are built in layers.** To build curved furniture parts, glue up blocks of wood in rings or arcs, and then layer them. The technique is strong and versatile, as shown in the circular apron in the glass-topped imbuia table.

Building furniture is a pretty linear process, as long as the parts are straight, the joinery is simple and the framework is rectangular. But many pieces aren't straight at all (see the inset photo above). Tables can have curved aprons and edges. Mirror frames are often oval or circular in shape. Drawer fronts can be serpentine. So what do you do when a piece of furniture throws you a curve?

I've found that segments of wood, glued together like a mortared wall, are just what the doctor ordered to make strong, stable curves. I first used this construction method, known as bricklaying, in 1975 while serving my patternmaker apprenticeship. I rarely make wooden patterns anymore, but I continue to use the bricklaying technique for curved furniture components. The bricklaid form can be a full circle, an arc or any curve. For strength, a curve needs at least two layers of glued-up segments, but three or more is best. A single layer isn't strong enough unless you use some additional joinery, like splines, biscuits or dowels

to bridge the butt joints between individual segments.

Just as with ordinary laminations, I always make the bricklaid form oversize. That way, I can adjust the layout of the finished part onto the glued-up stock. Once the glue sets, I can cut joinery into the form and shape and sand it just like it is a solid piece of wood. In the case of a circular mirror frame (like the one that's described in the story on p. 88), the form is ring-shaped. Bricklaid curves can be more complex, but because the mirror frame is simple, it's a good example of how the technique works. First, though, it's helpful to see why bricklaid segments are so versatile and to understand the importance of making accurate templates.

## Why patternmakers use bricklaid segments

Patternmakers glue wooden blocks together like layers of bricks to build the curved areas of wooden patterns, which are full-sized models used to form molds in sand. The sand molds are then used to cast metal (for more on this, see the story on pp. 90-91).



**Tempered hardboard is ideal for templates.** Use a trammel, a straightedge and a knife to scribe a template for a segment of a circular frame. Then trace the template onto stock.



**To get tight butt joints, trim the ends carefully.** After bandsawing the segments, the author disc sands their ends just to the knife line (darkened with pencil). He'll sand inner and outer curves later.



**Gluing up the segments.** To form rings, apply glue to the ends of the segments; then rub the ends together to force out any air from the joints. A polished stone slab, as flat as a patternmaker's surface plate, makes an easy-to-clean assembly table.

## Making a circular frame

The teak mirror frame in the photo at right consists of two ring layers, each with six segments. To make the frame, determine its inner and outer diameter. Have the mirror glass in hand so you can make the inner diameter of the frame 1 in. smaller, allowing for a 1/2-in. rabbet in the back of the frame. Next make a segment template (see the main article).



**It's hard to tell this mirror frame is made of segments.** The reason is that all the joints between segments and between layers are tight.

If you select a big enough board, all the segments will have the same color and characteristics. If not, cut the wood for the most visible layers from the same board. Using the template, trace out 12 segments onto 3/4-in. stock. Bandsaw and sand the segment ends. Next glue up half-rings of segments, flipping every other one. When dry, true up where the halves will be joined. Flip opposite halves, and glue them into full rings. After the glue has cured, scrape the joints, so you can stack and glue two rings together. Clamp the form, and let it dry.

Trim the frame, and rout the back rabbet for the mirror. Using a roundover, chamfering or molding bit, ease the inner edge of the frame, and add an outside profile. Final-sand, apply a finish and then inset the mirror in the frame. —K.K.

The pattern can be reused to make many molds.

Patterns must be strong and stable. As long as the wood grain in the segments is about the same density and runs the same way (no short grain), movement of the form due to moisture exchanges should be uniform. In bricklaid circular and spherical structures, the grain configuration is especially important because the form must expand and contract concentrically without becoming oval-shaped. After a pattern has been used at the foundry, it is usually retired to a warehouse. It may sit there for years before it's needed again. This is another reason why patterns must be strong and hold their shape over time.

### Segments are ideal for bowls and furniture

Bricklaid segments are common in woodturning. Stack-laminated segments can prevent bowls from warping. The grain of the segments can be arranged so that the bowl appears homogeneous. Or different woods can be used to make contrasting segments (for more on this, see *FWW* #64, p. 48). Layers can be built a couple at a time and once the glue has set, turned to make large, deep bowls safely. That way, you don't have to reach way inside the bowl with your tools.

Aside from circular shapes, you can bricklay wood into partial curves, such as arched door and window frames; waves in sculpture; and aprons for oval and semielliptical tables. I used this technique to form the built-up table edge in a large conference table.

Complex furniture parts can be bricklaid, too. For example, to create flowing lines in a contemporary glass-top table (see the inset photo on p. 87), I bricklaid segments of imbuia that were all cut

## Bricklaying a six-segment ring

### Step 1

Use hardboard template to lay out and scribe segments on stock.

Segments are  $\frac{1}{4}$  in. over-width to allow machining stock later.

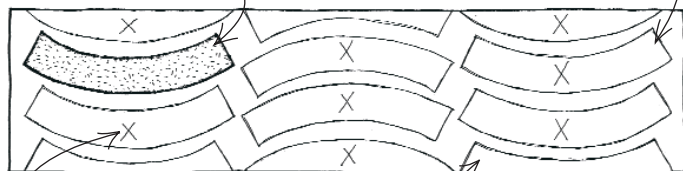

Mark X's on top side of each segment.

Glue this piece to the run-off segment above.

Grain direction runs lengthwise, never across.

### Step 3

Glue both sides of rings being stacked.

Arrange clamps every 4 in.

Hand screws span joints.

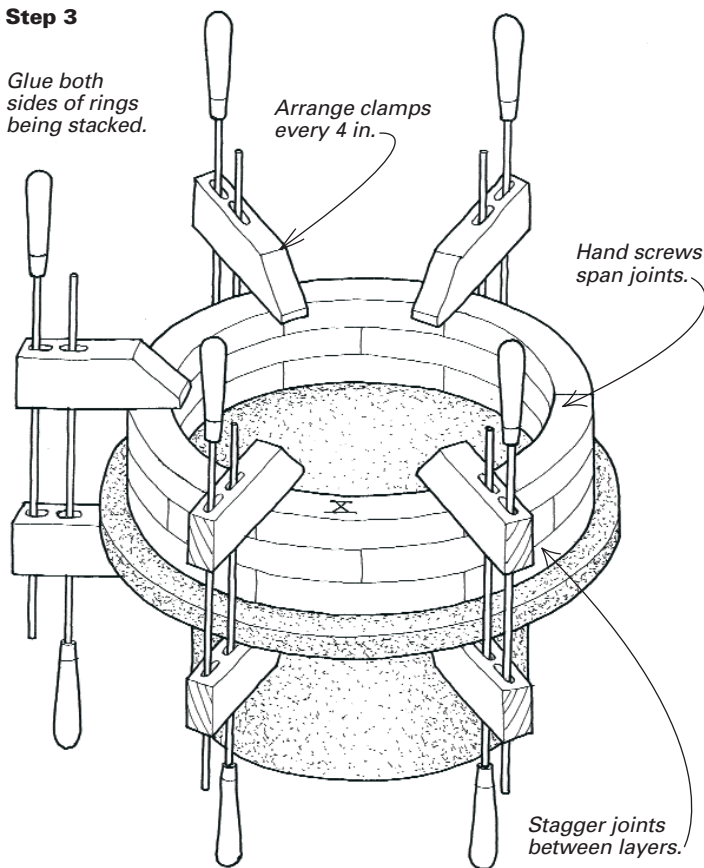

Stagger joints between layers.

### Step 2

Cut out and sand segments; then dry-assemble to check fit. Glue pieces into half rings. Let dry.

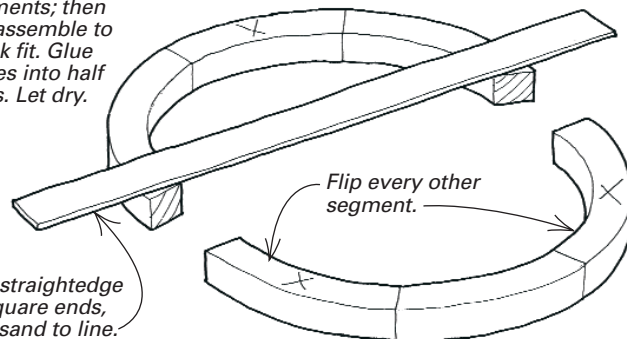

Flip every other segment.

Use straightedge to square ends, and sand to line.

Flip opposite ring halves, and glue up into full rings. Let dry.

### Step 4

Use a trammel to re-scribe outer and inner layout lines.

Insert and tack stick to give center point.

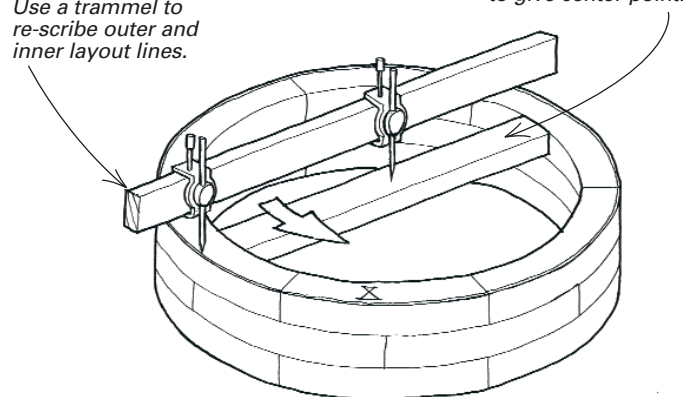

Drum sand inner border; then disc or beltsand perimeter.

### Detail: Sanding to scribe lines

Scribed layout lines are more accurate than pencil lines.

Burr lifts and peels away as you approach bottom of "V."

"V" made by point or knife blade

Disc or beltsand to layout line.

Workpiece

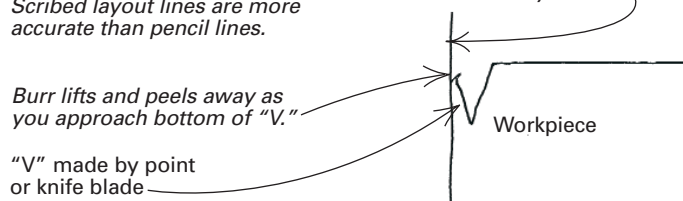

from one board, and then I shaped them with a router jig and hand tools. The offset segments in the bottom layer provide sockets for the three legs—another advantage of the technique.

### Strength comes from layers

Bricklaid forms derive their strength from bonded layers. The butt joints between segments are relatively weak because only end grain is being glued. To give those joints integrity, it's critical that the template used to lay out the segments be exact and that the segment ends be cut and sanded precisely to make the joints tight. By contrast, the bonds between adjoining layers of segments are strong because long grain is glued to long grain and because

each segment bridges a joint. This is why the joints in adjacent layers must be staggered (see the drawing above).

### Start by making a segment template

I start by making a template for the segments using  $\frac{1}{8}$ -in. hardboard like Masonite. For bricklaid forms that are full circles, I use six segments. This process requires only simple tools and basic geometry, which makes layout a breeze. But if you need to make an arc shape or curve with an odd number of segments, you can look up the proper angles and chord lengths from charts often printed at the back of geometry and trigonometry textbooks. For tools, you'll need a scribing knife, a steel straightedge and a trammel, which is

basically a large compass (see the top photo on p. 88). You can buy the trammel at most woodworking-supply stores.

To lay out the template for a six-segment circle, set the trammel  $\frac{1}{8}$  in. less than the finished inside radius you want, and scribe about a quarter circle onto your piece of hardboard. Next, using the same center, scribe a quarter circle  $\frac{1}{8}$  in. larger than the desired outside radius. Without changing the trammel setting, place one point on one end of the outside arc, and using the other point, drag a small hash mark across the outside arc. Now lay a straight-edge from each point back to the center point, and scribe the ends of the segment (see the top photo on p. 88).

If you were to draw a full outside circle, you could use the same radius setting to step off points around the whole circle. You would get six equal divisions and end up at your starting point. Each of the six chords would be the same length as the radius. This is also an easy way to draw a hexagon or, by skipping every other mark, an equilateral triangle.

Bandsaw out the template, and drum sand the inside radius with a sanding drum mounted in a drill press or an oscillating spindle sander. Next take the template to the disc sander. If you don't own a disc sander, clamp your belt sander on its side. Make sure that the platen is perpendicular to your benchtop and that the belt can spin freely. As you sand the template, go easy, especially on the ends where the segments will contact one another.

The beauty of using scribed lines is that when you've sanded just up to the line (the bottom of the "V" made by the knife edge), a tiny burr will form and peel off the end (see the detail in step 4 on p. 89). So that you don't change the angle on the template ends, ease the piece into the disc (or belt) until you see an even burr lifting all along the top edge. Once you've sanded both ends, you'll wind up with a template for a six-segment, one-layer ring. The extra  $\frac{1}{8}$  in. on the inside and outside circumference will allow for machining to exact size.

### Lay out and cut the segments from stock

Select your stock, and plane all the boards to the same thickness. Trace out all the segments, so the grain runs lengthwise. If your wood is especially precious and you can permit a glue joint in the segments, lay them out close to each other across the width of the board, so they look like stacks of arches. Let the last segment run off the stock. Then glue up the waste from the other side (under the bottom arch) with the incomplete segment to make a full one (see step 1 on p. 89).

Bandsaw out all the segments, leaving a bit of your pencil line. Then go back to the disc sander, and just as with the template, carefully sand the segment ends (see the center photo on p. 88). Your disc sander's table angle could be slightly off, so mark all the segments with an X to identify the top side. You can cancel out any sander error by flipping every other segment when you glue up the ring (the X's let you keep track). Before you glue up, though, check your joinery by dry-assembling the form.

### Glue up segments, then layers

If everything checks out, glue up the first layer. It's easiest to form half circles—groups of three segments—and then join the halves. Glue on a dead-flat surface, such as the machined top of your tablesaw (protected by plastic). I use a big polished gravestone as a surface for gluing up. When joining two segments, apply glue to both ends being joined, and rub them together as they lay flat (see the bottom photo on p. 88). Rubbing the joint will press out any air, which would compromise the glue bond. Stop rubbing when the segments come into line. You shouldn't need to clamp the segments, but if a particular joint wants to open up, span it with a

## Patternmakers: masters of wooden curves

by Alec Waters

I peeked into the cavernous warehouse and saw what looked like spare parts for the Tin Man. The character in *The Wizard of Oz* came to mind because I was surrounded by hundreds of silver-painted wooden patterns. I was visiting the patternmaking shops in Atchison, Kan., where Kirt Kirkpatrick had learned his trade.

To see the fruits of a patternmaker's labor, look in your own shop. Your jointer tables and tablesaw trunnions probably are cast iron and each required a pattern at one time. The pattern was used to make an impression in sand—the mold for the casting. All the patterns I saw were unrecognizable, though. The more complicated ones looked like jigsaw puzzles.

When you're making impressions for a mold, the pattern has to be exact in size and shape. The casting will faithfully reproduce whatever is molded in the sand. In areas that won't be machined, the clearances can be critical, and the tolerances can be close.



**Guiding molten metal at the foundry**—Wearing a fire-proof suit, a worker at this Atchison, Kan., foundry guides a ladle as it pours liquid-hot alloy. The flask (frame), containing compacted sand, has an upper (cope) mold and a lower (drag) mold that were formed with wooden patterns.

pinch dog, lightly driving the prongs into the adjoining segments. Only do this if the holes created by the prongs will be buried by another layer or will be in an unseen part of the project, such as the back of a mirror frame. Let things dry.

After you have all the half-circle groups glued together, take a straightedge and draw a line across the ends of the outside segments. This will create a straight surface (like a diameter) where the half circles will be connected (see step 2 on p. 89). Use the disc sander to sand to these lines. Be sure to mark each group with an X, as described previously, and flip one of the halves. Glue the half-circles into full rings.

Once the glue has cured, you can either run the rings through a wide-belt sander, or you can scrape and sand the joints until the tops and bottoms are flat. Then as you glue the rings together, be

For example, the casting for an aircraft part often can't stray more than 0.010 in. to 0.015 in. from the dimensions shown on the blue print. To achieve this, the pattern must be oversized so that when the casting cools, it will be the intended size. Kirkpatrick told me of one pattern that was a few thousandths of an inch shy in places. It had to be sprayed with thin coats of lacquer to bring it up to specification.

When a pattern is laid out, the patternmaker has to allow for the contraction of the metal in the mold as it cools off. To compensate for the change in dimensions, shrink rules are used, which have built-in shrinkage factors based on the metal being poured (see the photo at right).

Wood is the logical choice for patterns because it is relatively inexpensive, strong and tools easily. Patternmakers prefer woods that are dimensionally stable and shape consistently. The stock should have grain that is straight and tight. There should be no figure and no defects, such as knots or checks. For these reasons, clear mahogany and sugar pine are commonly used. If a pattern is too big to be made of solid wood, it can be made from bricklaid segments or from beveled, tapered pieces, like staves for a barrel. To sculpt the wood, patternmakers use bandsaws, routers, shapers, grinders and sanders (see the top photo).

Most patterns are made in two parts: the pattern, which describes the outside of the casting, and the core box, which forms the interior (cavity) shape. Core boxes can be complex, so they're made in sections, which can be removed without disrupting the sand. Each side of the pattern is slightly tapered, called draft, to allow the part to be withdrawn. Pieces often interlock or overlap (see the bottom photo), and frequently they are painted to indicate the order of assembly or the relationship to other pieces. Parts often will have appendages for anchoring, gas venting, cooling and pouring.

As soon as the pattern is assembled, it's coated with a release agent, such as non-stick paint or powder. Then a frame that looks like a big sand box is prepared to hold the bed of sand. The sand is mixed with binder additive to make it compact better.

sure to stagger the segment joints from one layer to the next. Apply glue to both surfaces. Repeat stacking and gluing layers until you achieve the form thickness you need. If you are forming an arc, follow the same basic procedure. Finally, clamp the form generously around the circumference (see step 3 on p. 89).

### Mark and trim the form to final size

You'll need to make a center point on the same plane as the top of your form, so you can re-scribe the outlines with the trammel. To do this, fit a stick of wood between the opposite inside edges of the laminated form. The stick should look like a diameter. You can secure it with hot glue, auto-body filler or tack it with tiny brads (you'll be trimming off any adhesive residue or nail holes later). Use the trammel to find the center point on the stick, allowing



**A disc sander is indispensable in a pattern shop.** Using a 42-in. disc sander, Terry Scholz shapes a glued-up block, called a riser. The riser will be used to make a sand impression for a metal reservoir used in the casting process.



**Tools only a patternmaker knows—Starrett squares and the Emmert vise are familiar to most woodworkers.** But other items on this bench, like the ball-ended fillet irons and shrink rules (center), are best known by patternmakers.



**A complex pattern from many pieces.** To make a casting for a welding robot, Wilson Bros. Pattern Co. built this mahogany pattern. Each part is scribed on a painted hardboard layout board.

The last stop on my tour was watching a casting being made at one of the biggest foundries west of the Mississippi. As a pickup-truck-sized ladle of molten steel headed toward a sand mold (see the photo on the facing page), I suddenly realized the significance of all the patternmaker's meticulous work. If there were any errors in the pattern that made the sand mold, lots of money, labor and time would be poured down the drain. □

*Alec Waters is an associate editor for Fine Woodworking.*

enough excess stock all around the form for clean up. Re-scribe the inner and outer circles with the trammel (see step 4). If the form is shallow (say, two or three layers deep), you probably won't need the stick. Just secure the ring over a piece of hardboard marked with a center point, and extend one of the trammel points to re-scribe the boundaries. These should pretty much match the pencil lines you drew when you were tracing the individual segments. Use a drum sander and a disc or belt sander to trim the form to the new lines. If you have a big lathe, you can mount the form to a faceplate, and turn it down to your scribe lines. □

*Kirt Kirkpatrick lives in Albuquerque, N.M. Formerly a journeyman patternmaker and boat builder, he now carves and builds furniture and doors.*

